

HULALA
H O M E

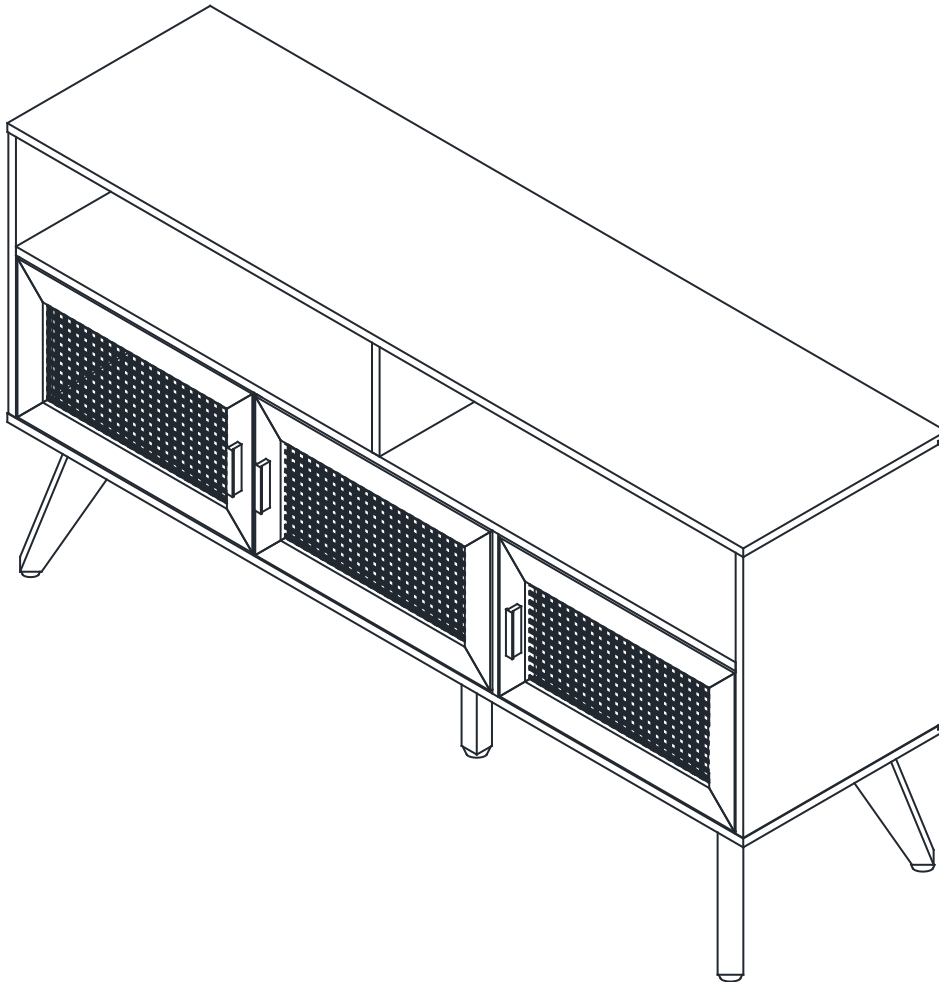

ITEM NO. TVSBSD0453

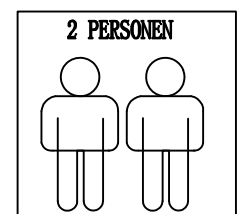

NOTE:

This brochure contains IMPORTANT safty info. Please read and keep for future reference.

MAINTAINANCE

AND WARNING

- Keep furniture away from heat.
- Do not clean furniture with harsh cleansers or polish. Do not use detergents, Solvents, abrasives, spray packs or leather cleaner. Use non-color mild soap with warm water clean spills(Mix 1:10 soap to water)
- Do not place furniture under direct sunlight, material will possibly fade over time.
- Do not use on site dry Cleaning machine.
- Children should not climb or jump on the furniture.
- Do not write on furniture without a padded barrier to protect the surface.
- Not for commercial use, For residential use only.



Weight Limitation

80LBS

PARTS LIST

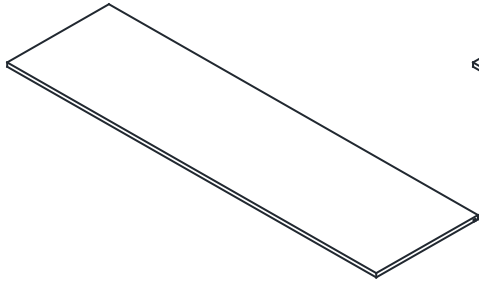

① x1

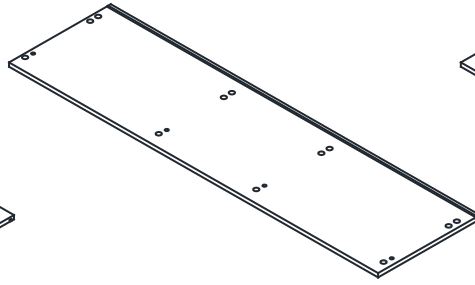

② x1

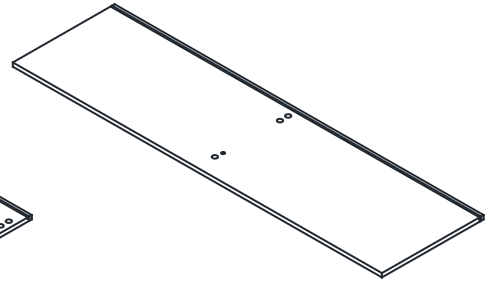

③ x1

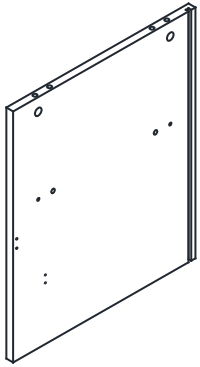

④ x1

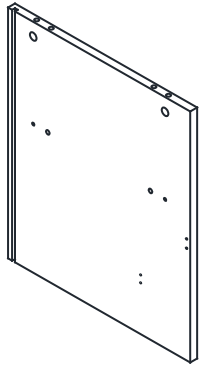

⑤ x1

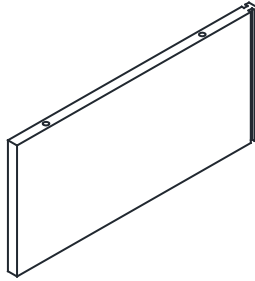

⑥ x1

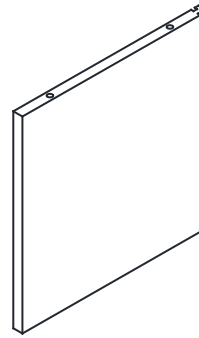

⑦ x1

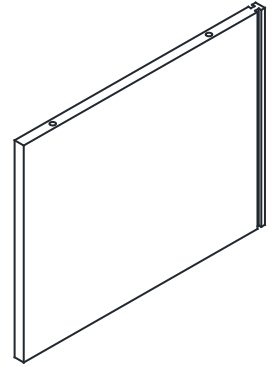

⑧ x1

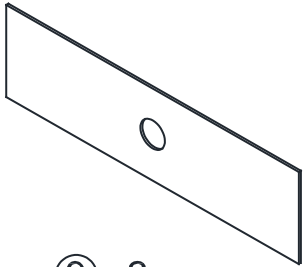

⑨ x2

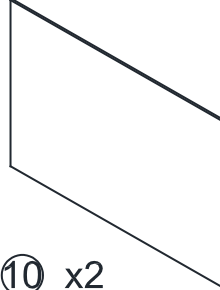

⑩ x2

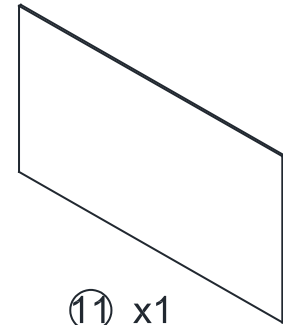

⑪ x1

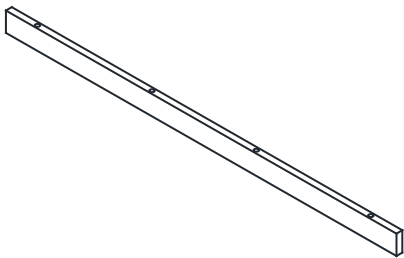

⑫ x2

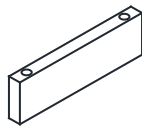

⑬ x2



⑭ x4



⑮ x1

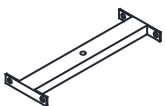

⑯ x1

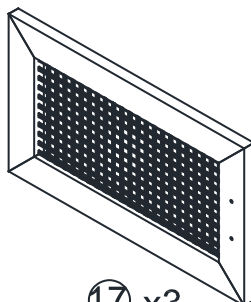



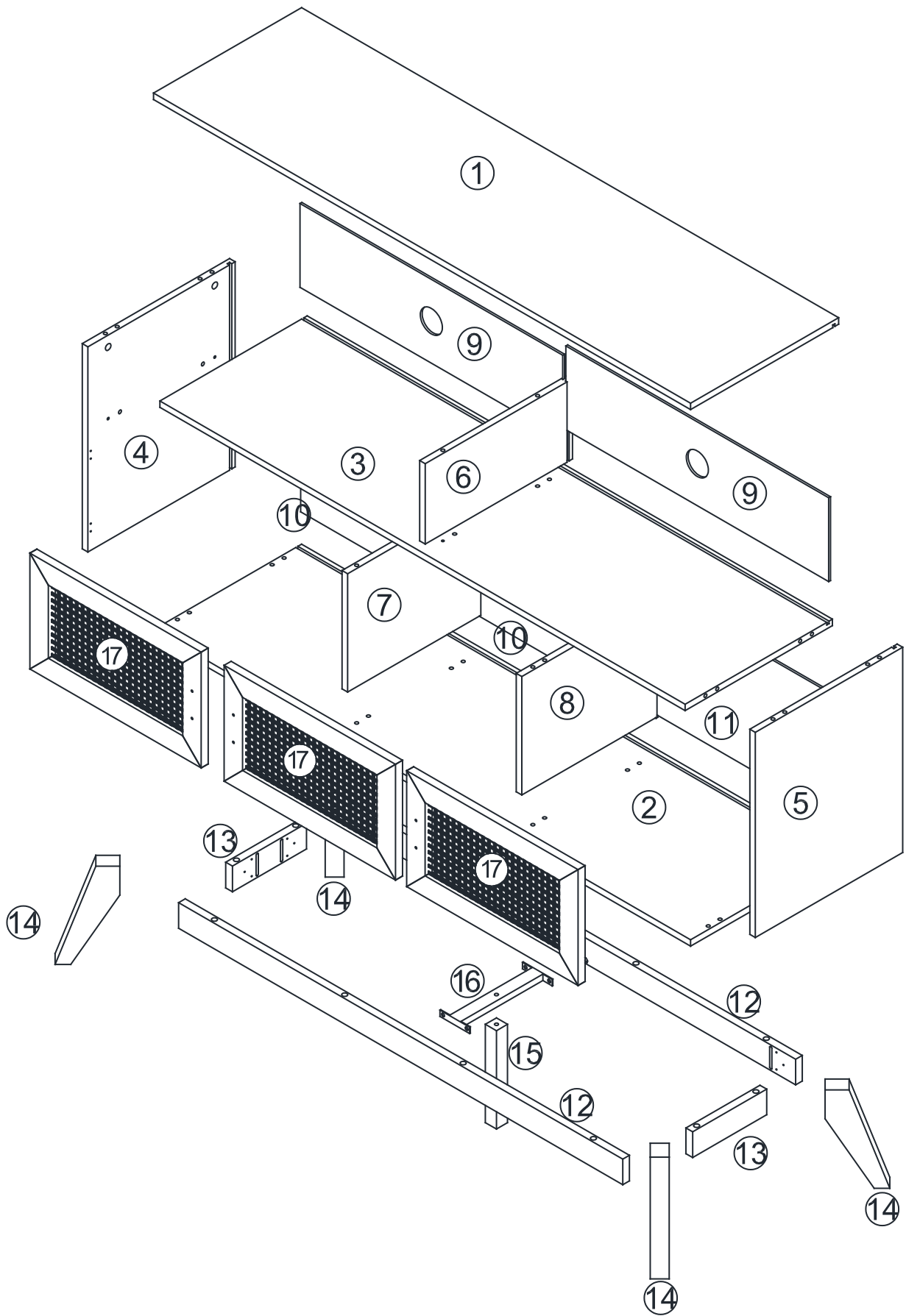



















⑰ x3





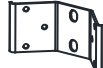





Explosive View

HARDWARE LIST

A	x14	B	x14	C	x10	D	x24	E	x96	F	x20	G	x3	H	x6	
																
M6*35mm		Ø15mm		M7*50mm		Ø8*30mm		Ø3.5*14mm						M4*22mm		
I	x4	J	x12	K	x1	L	x8	M	x4	N	x6	O	x14	P	x1	
																
M6*12mm		M6*60mm		M6*30mm		M6*40mm		Ø4*35mm						M4		
Q	x2	R	x4	S	x2	T	x4	U	x6	V	x4	W	x1			
																

SPARE

A	x1	C	x1	E	x1	H	x1	I	x1	J	x1	K	x1	L	x1
															
M6*35mm		M7*50mm		Ø3.5*14mm		M4*22mm		M6*12mm		M6*60mm		M6*30mm		M8*40mm	
M	x1														
															
Ø4*35mm															

Be sure to check all packing material carefully for small parts, which may have come loose inside the carton during shipment.

ASSEMBLY INSTRUCTIONS

STEP 1

Prepare the part 4, 5 and middle leg.

- 1) Assemble the middle leg. Align the hole in part 16 and the screw hole in part 15, screw in and tighten the screw K by allenkey P.
- 2) Align the hole in part 4, 5, insert the wooden dowel D into the hole by hand; screw in and tighten the cam bolt A by screwdriver W

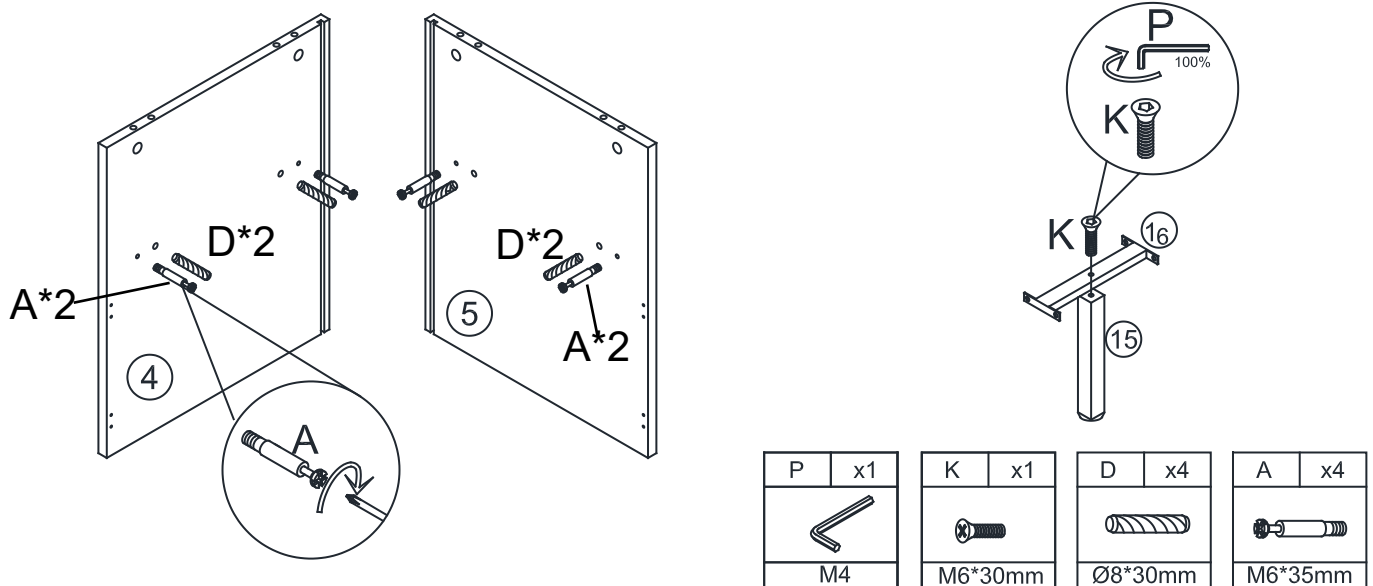

STEP 2

Connect part 3 to the part 4 and 5.

- 1) Align the hole in part 3, insert the wooden dowel D into the hole by hand;
- 2) Insert the nut B into the hole in part 3, Align the hole in part 3, insert the part D and cam bolt A in part 4 and 5 into the hole in part 3, screw in and tighten the nut B by screwdriver W.
- 3) Cover the nut by part O.

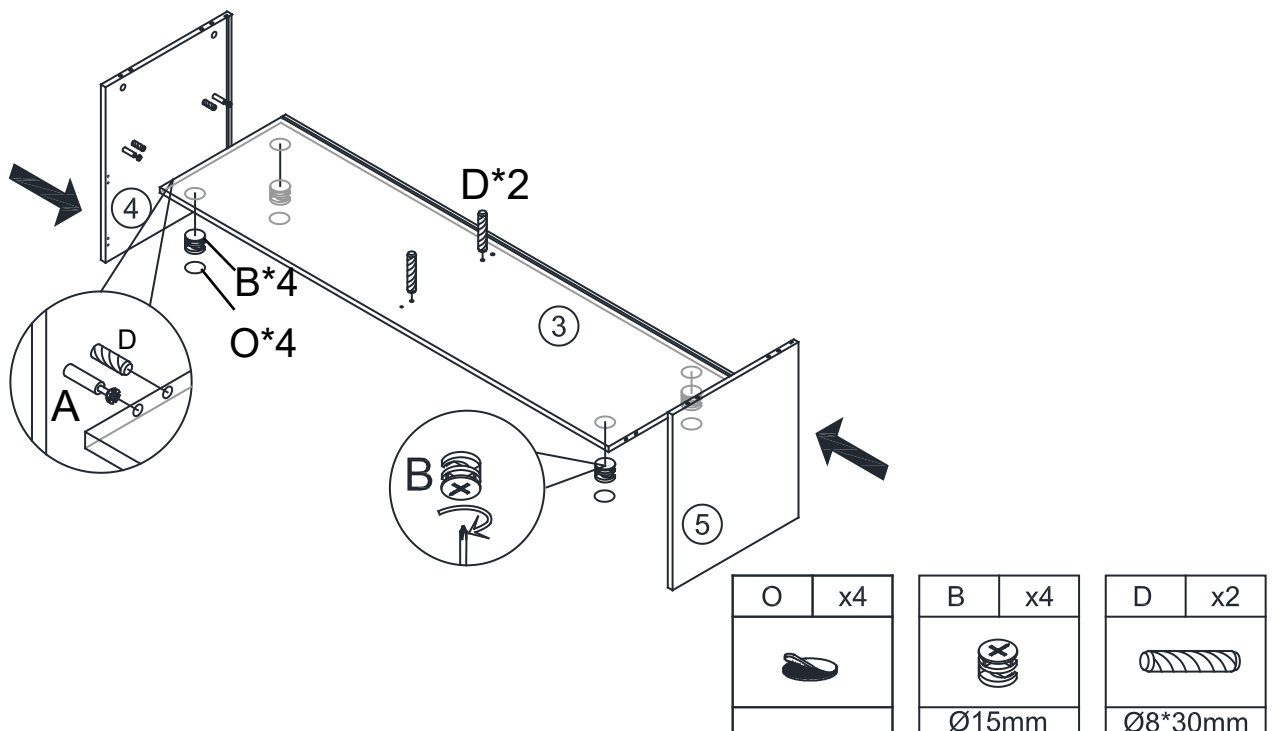



STEP 3

Connect the part 6 to the finished part in step 2.

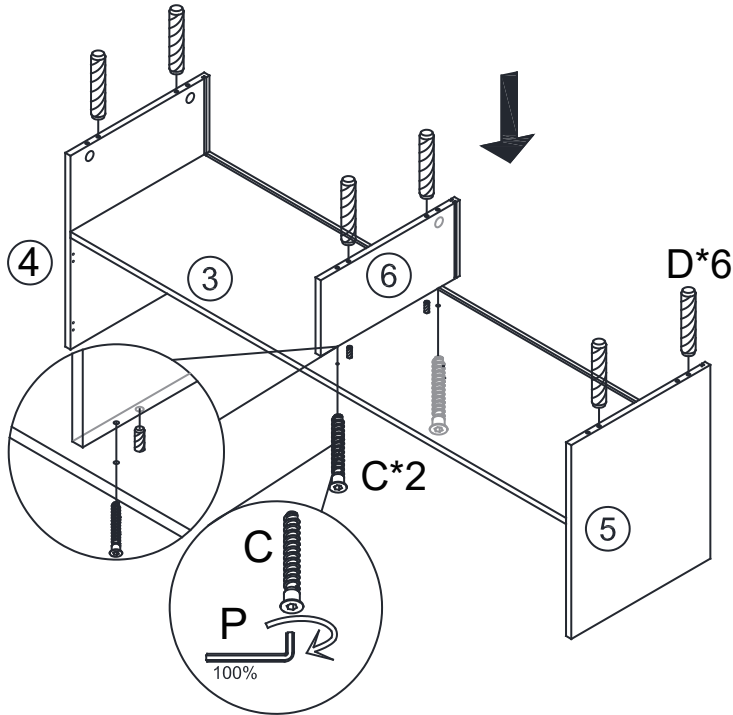
- 1) Insert the wooden dowel D into the part 4, 5 and 6 by hand.
- 2) Align the hole in part 6, insert the wooden dowel D in part 3 into the part 6, then screw in and tighten the screw C by allenkey P.



P	x1	C	x2	D	x6
					
M4		M7*50mm		Ø8*30mm	

STEP 4

Connect the part 9 to the finished part in step 3.

- 1) Insert the part Q into part 9.
- 2) Slide part 9 into the groove of 3, 4, 5 and 6.

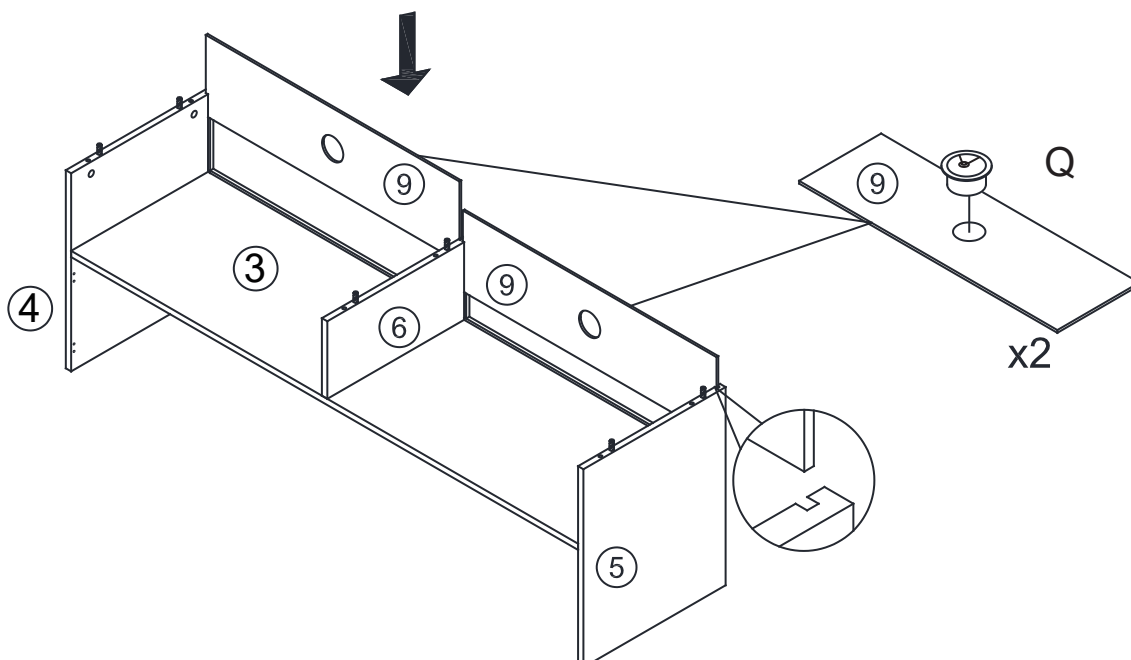

Q	x2
	

STEP 5

Prepare the part 1 and part 17.

- 1) Align the hole in part 1, screw in and tighten the cam bolt A by screwdriver W.
- 2) Align the hole in U to the hole in part 17, screw in and tighten the screw E by screwdriver W.
- 3) Align the hole in part 17 to the hole in part G, screw in and tighten the screw H by screwdriver W.
- 4) Align the hole in part N to the hole in part 17, screw in and tighten the screw E by screwdriver W.

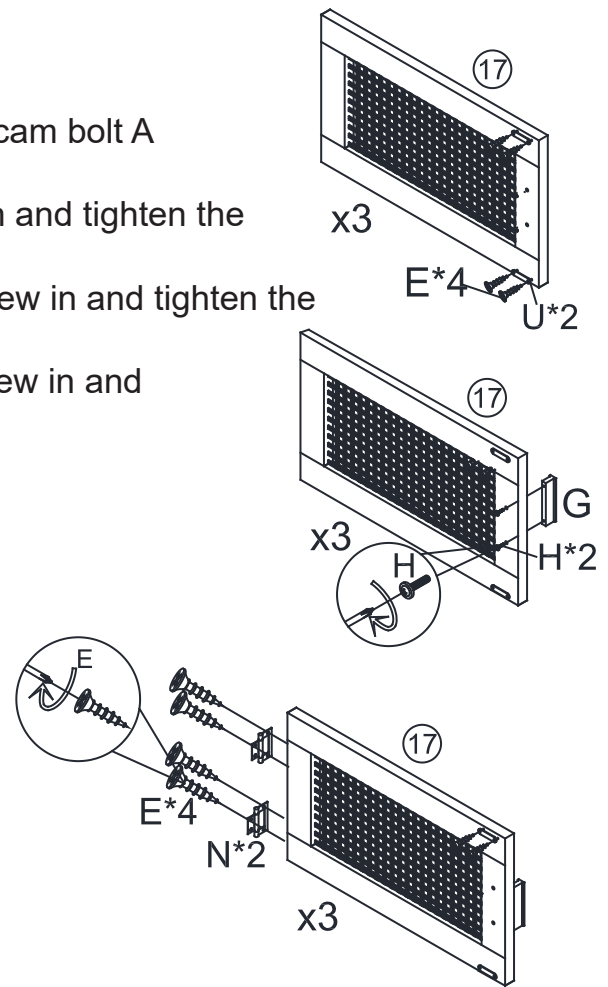
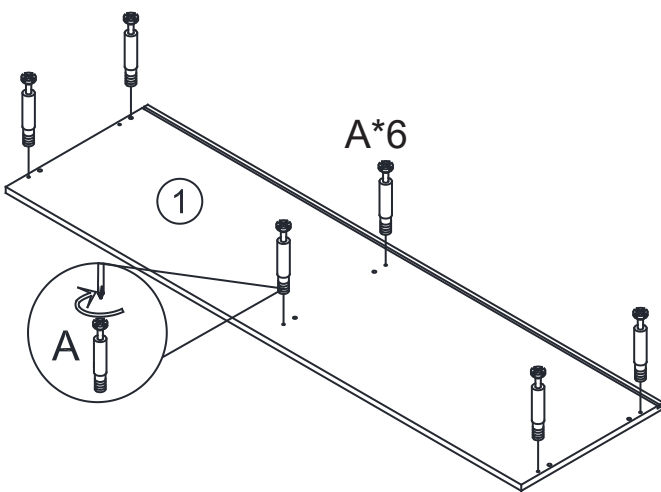

U	x6	G	x3	H	x6	N	x6	E	x24	A	x6
				M4*22mm				Ø3.5*14mm		M6*35mm	

STEP 6

Attach the part 1 to the finished part in step 4.

- 1) Insert the nut B into the hole in part 4, 5 and 6 as the picture show.
- 2) Align the hole in part 4, 5 and 6 to the cam bolt A in part 1, insert wooden dowel D and cam bolt A at same time, then tighten nut B by screwdriver W.
- 3) Cover the nut by part O.

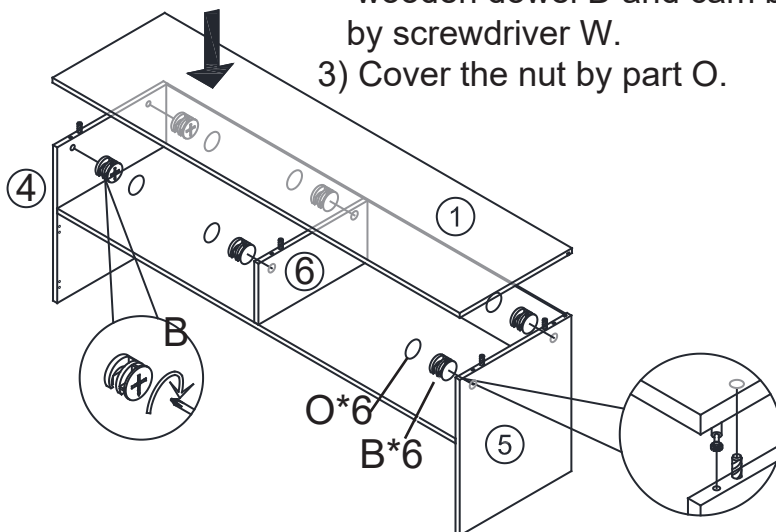

O	x6	B	x6
		Ø15mm	

STEP 7

Prepare the part 3.

- 1) Turn over the finished part in step 6.
- 2) Align the hole in part 3, 4 and 5 and insert the wooden dowel D into the hole by hand as the picture show.
- 3) Align the hole in part 3, screw in and tighten the cam bolt A by screwdriver W.
- 4) Align the hole in part U ,screw in and tighten the screw E by screwdriver W as the picture show.

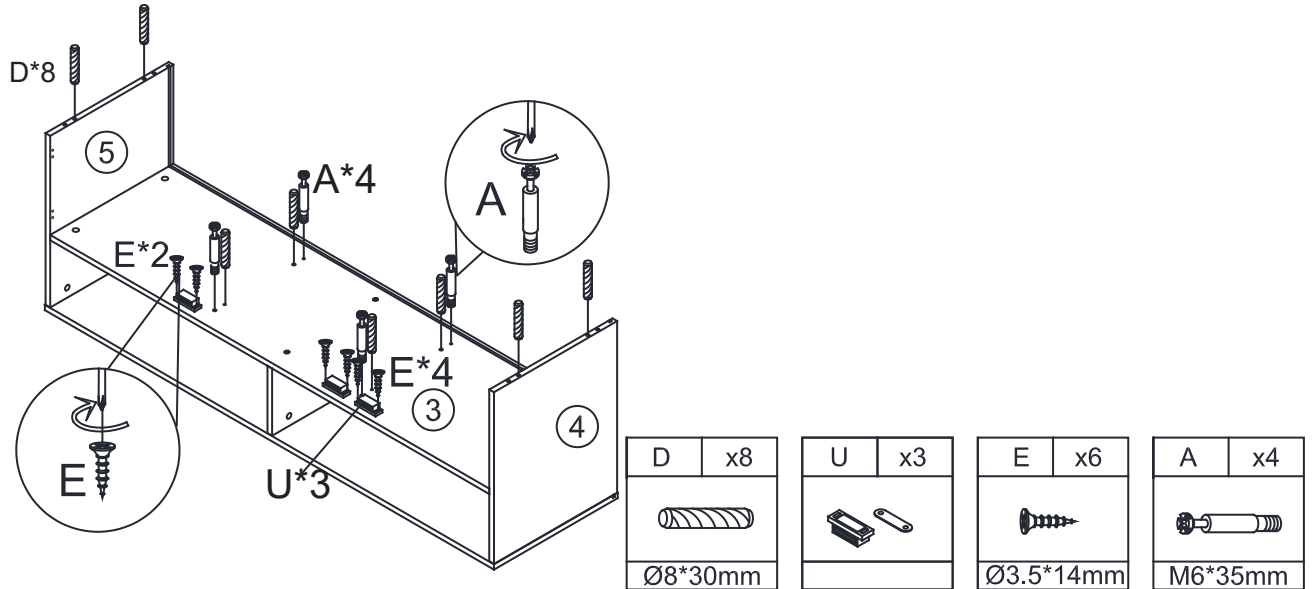

STEP 8

Attach the part 7 and 8 to the finished part in step 7.

- 1) Insert the nut B into part 7 and 8 as the picture show.
- 2) Align the hole in part 7, 8 to the wooden dowel D and cam bolt A in part 3, insert the part D and A into part 7 and 8 at the same time, then tighten the nut B by screwdriver W.
- 3) Cover the nut by part O.

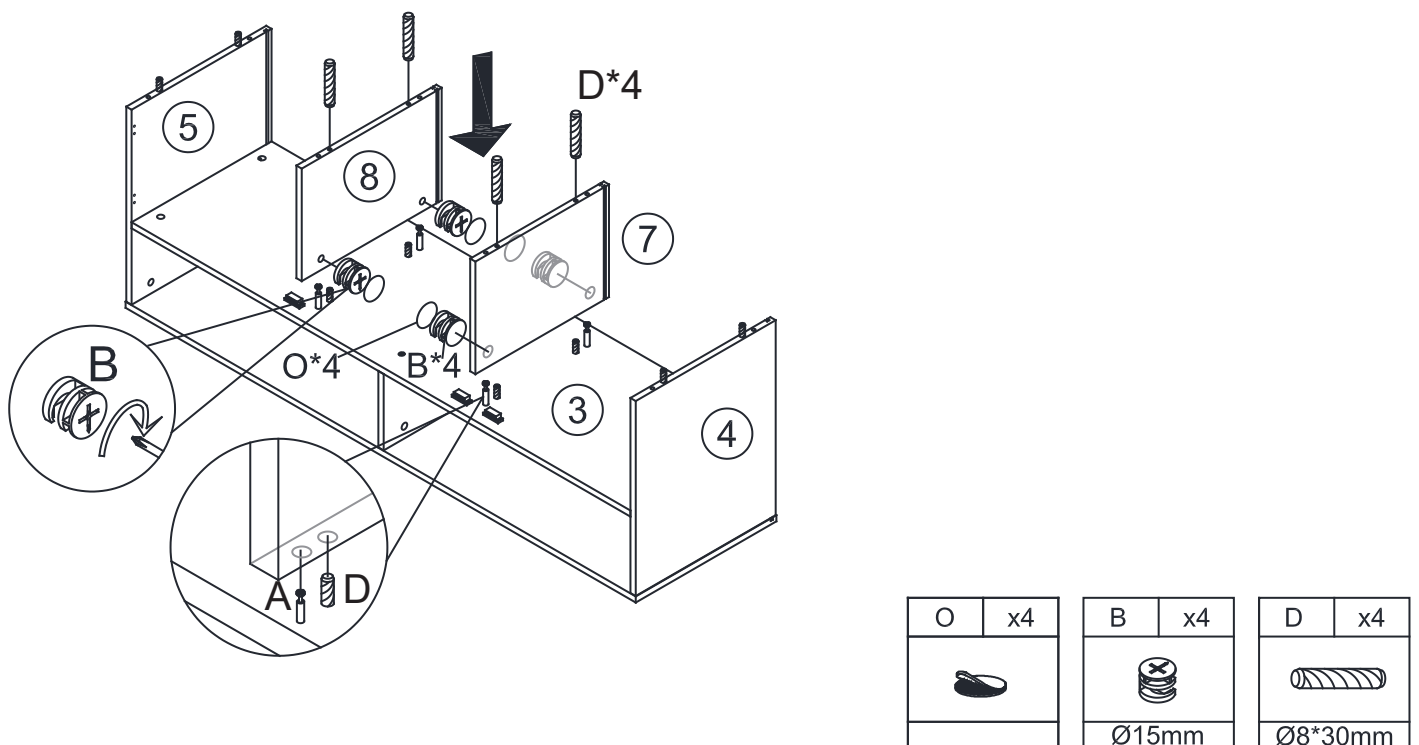

STEP 9

Slide the part 10 and 11 into the groove in part 3,4,5,7 and 8.

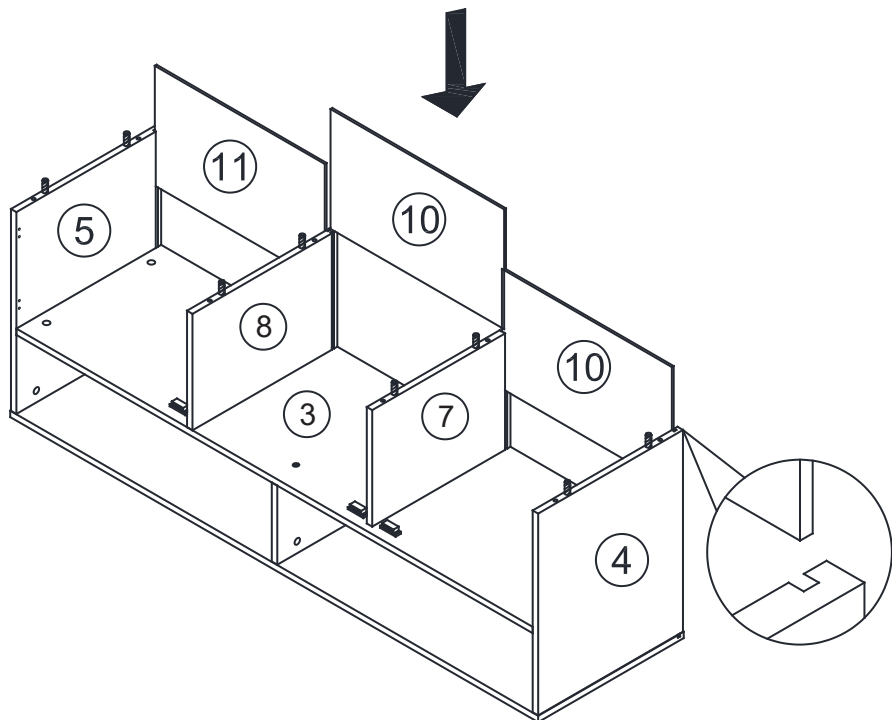



STEP 10

Attach the part 2 to the finished part in step 9.

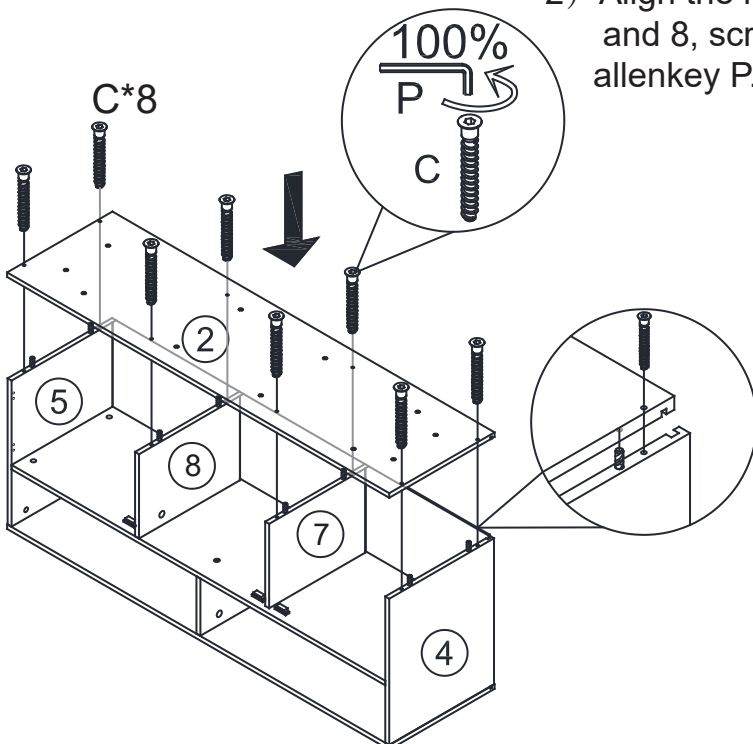
- 1) Insert the wooden dowel D in part 4,5,7, and 8 into part 2, then
- 2) Align the hole in part 2 to the hole in part 4,5,7, and 8, screw in and tighten the screw C by allenkey P.





P	x1	C	x8
			
M4		M7*50mm	

STEP 11

Attach the leg frame.

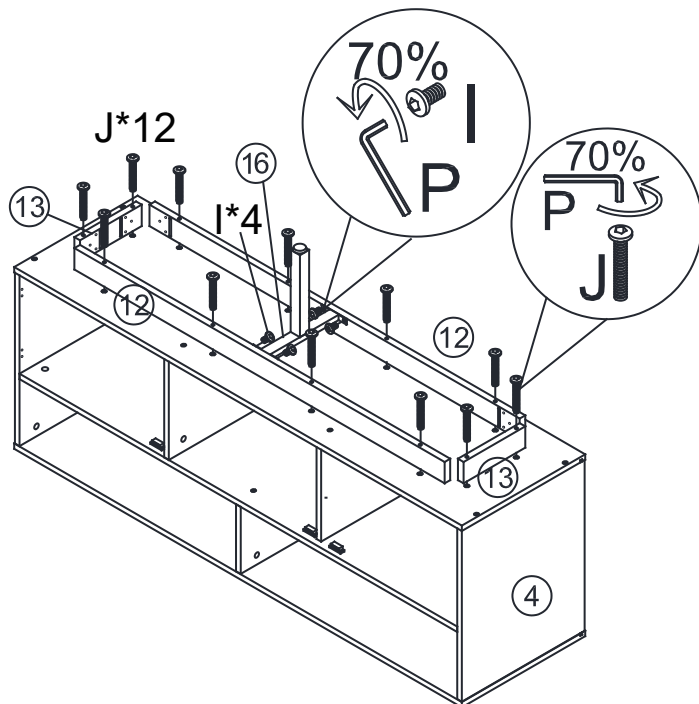
- 1) Align the hole in part 12 and 13 to the hole in part 2, screw in and tighten the screw J by allenkey P. **DO NOT FULLY TIGHTEN!**
- 2) Align the hole in part 16 to the hole in part 12, screw in and tighten the screw I by allenkey P. **DO NOT FULLY TIGHTEN!**



P	x1
	
M4	

I	x4
	
M6*12mm	

J	x12
	
M6*60mm	

STEP 12

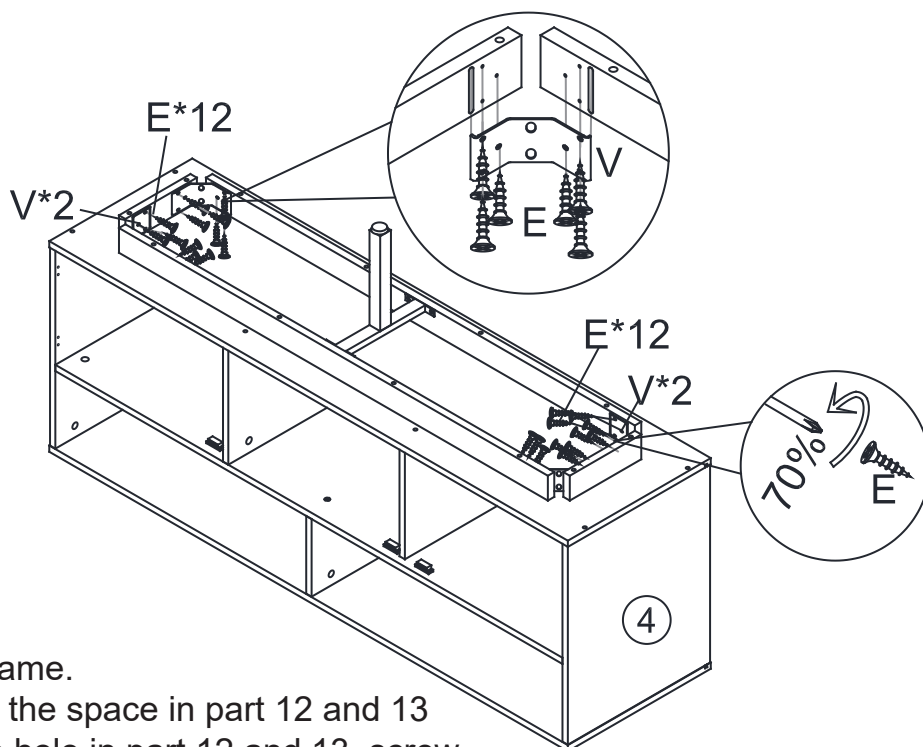

Assemble the part V to the leg frame.

- 1) Insert the edge of part V into the space in part 12 and 13
- 2) Align the hole in part V to the hole in part 12 and 13, screw in and tighten the screw E by screwdriver W. **DO NOT FULLY TIGHTEN!**

E	x24
	
Ø3.5*14mm	

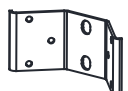
V	x4
	

STEP 13

Assemble the legs.

- 1) Align the hole in part 14 to the hole in part V, screw in and tighten the screw L by allenkey P.
- 2) After check the all screw in right position, fully tighten the screws I, J E in sequence.

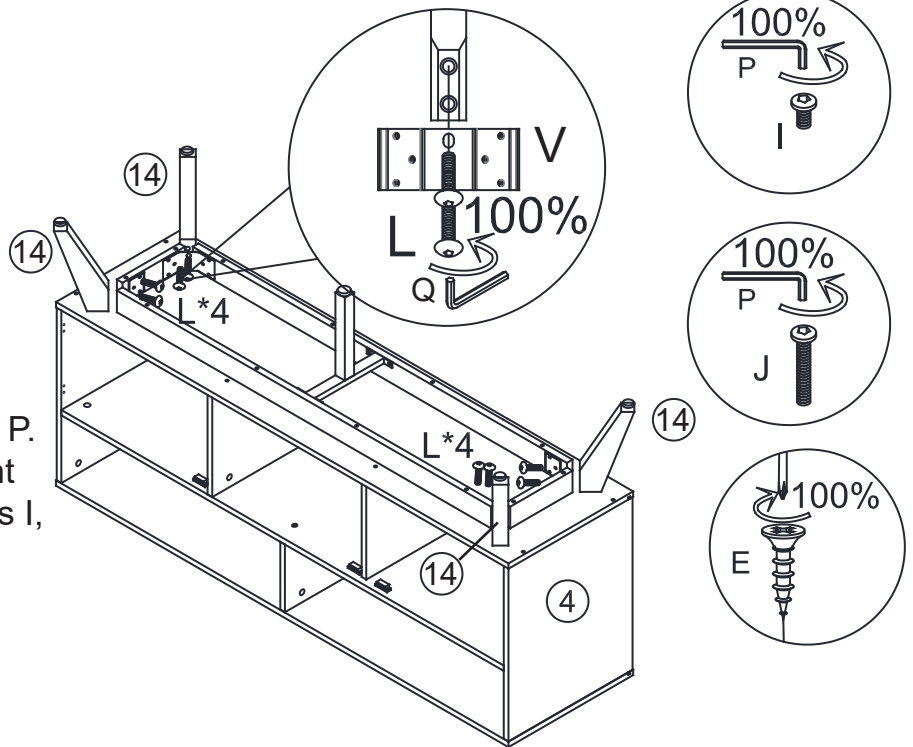



L	x8
	
M6*40mm	

STEP 14

Assemble the part F and part R (hook of anti-collapse) as the picture show.

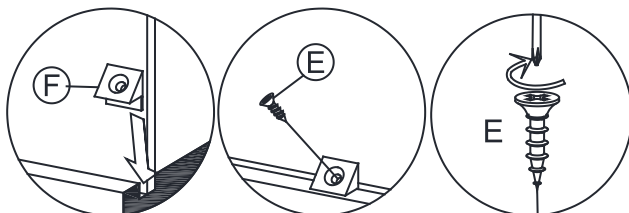
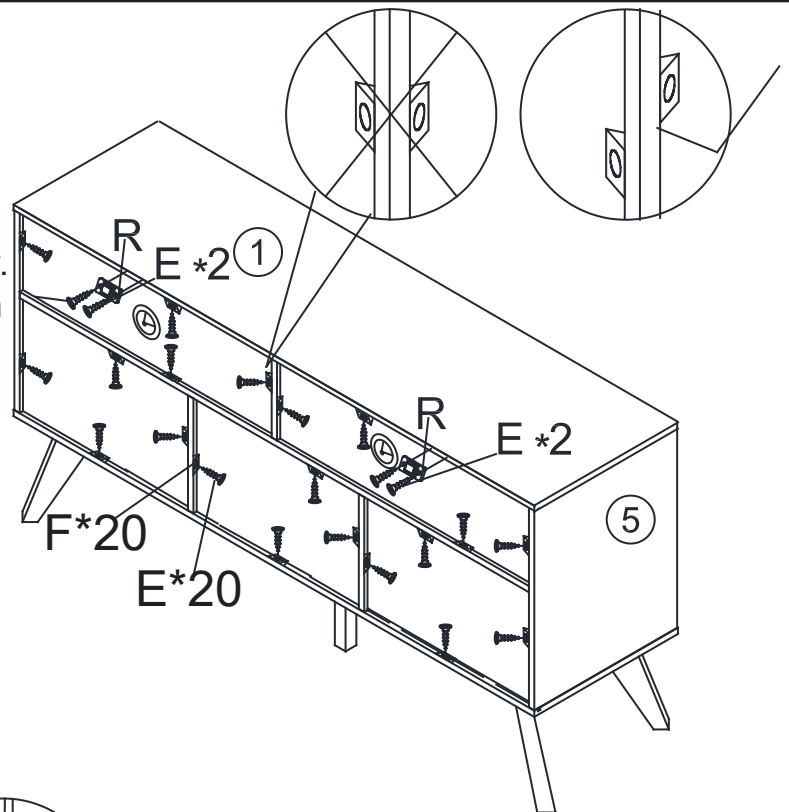
- 1) Insert the part F into the space between the part 1,2, 3, 4,5,6, 7, 8 screw in screw E and tighten by screwdriver W.
- 2) Align the hole in part R to the part 1, screw in and tighten the screw E by screwdriver W



R	x2
	

E	x24
	
Ø3.5*14mm	



F	x20
	

STEP 15

Attach the part 17 to the finished part in step 14.

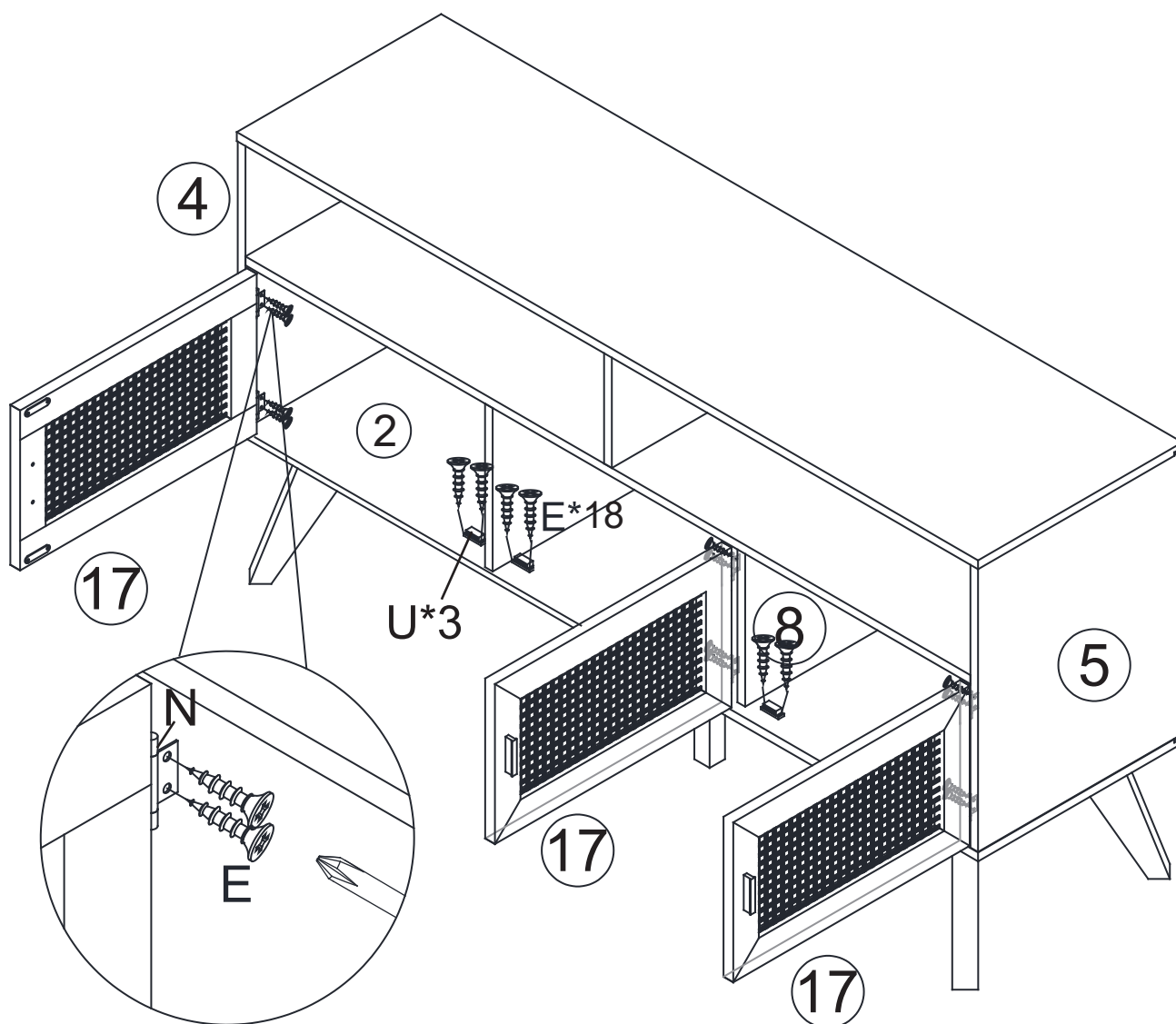
- 1) Assemble the part U in the part 2 as the picture show.
- 2) Align the hole in part N to the part 4, 5 and 8, screw in and tighten the screw E by screwdriver W as the picture show.



U	x3	E	x 18
			
		Ø3.5*14mm	

STEP 16

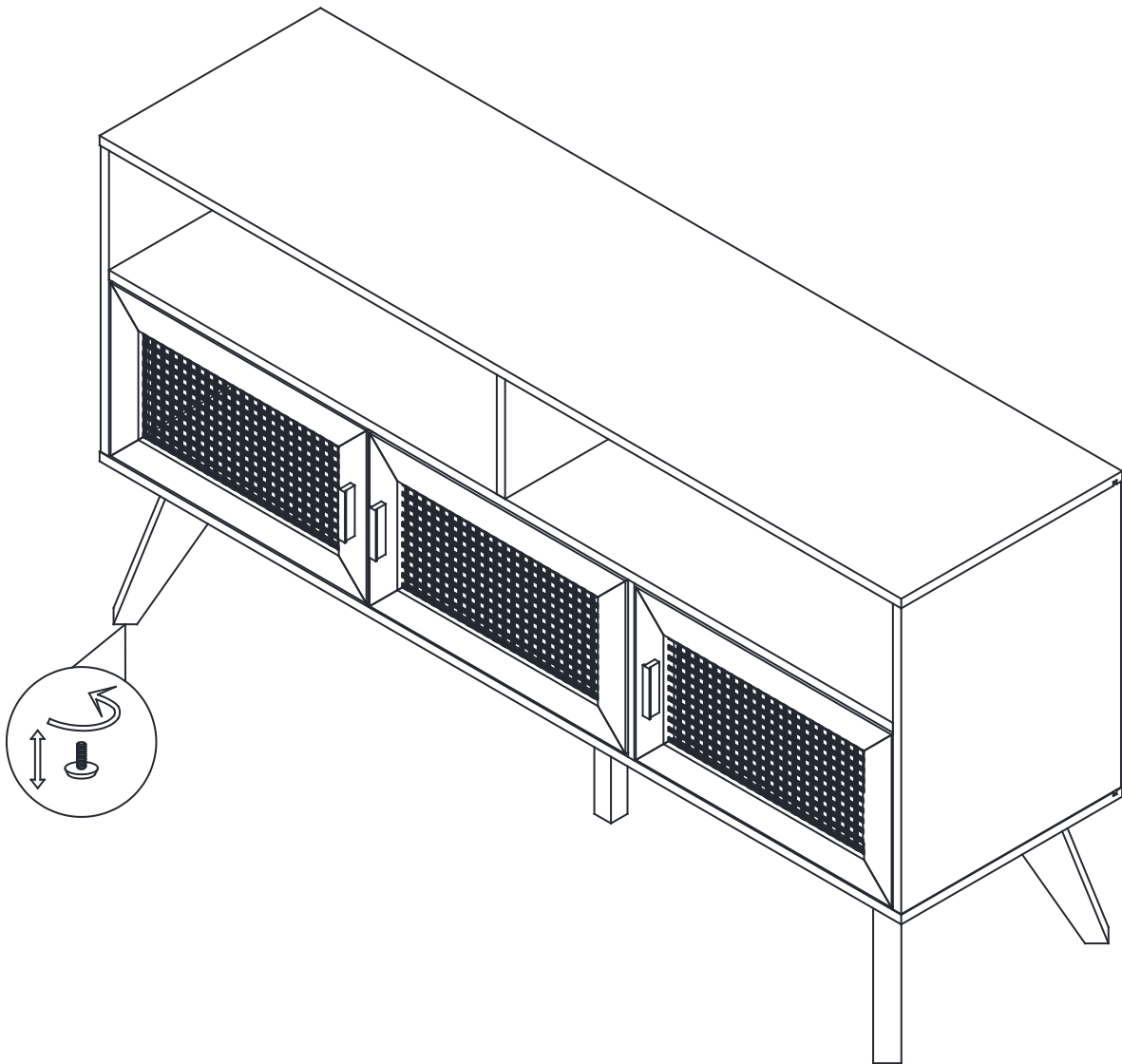



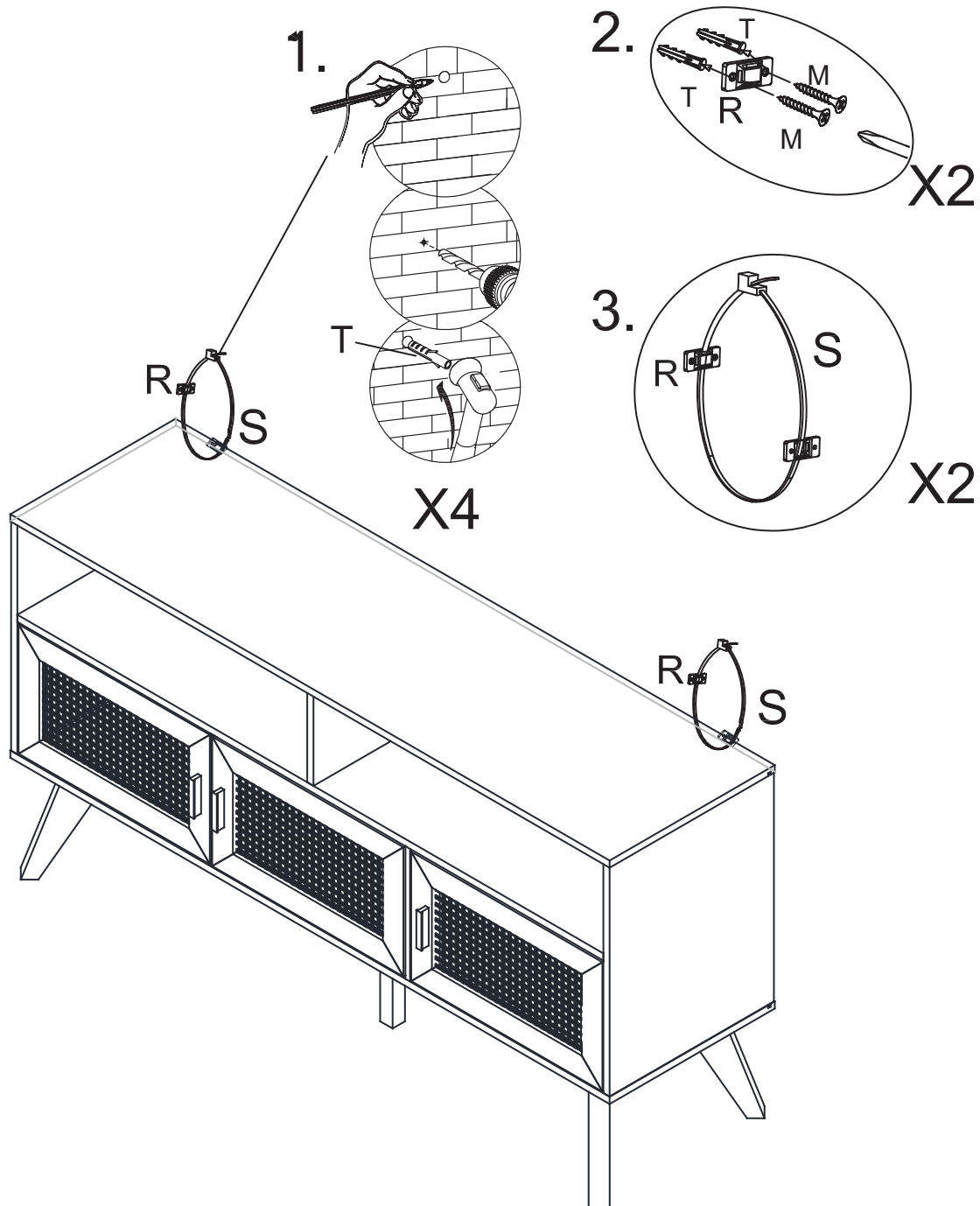

Use the adjustable nail to keep the cabinet level in case the cabinet is wobbling.
Now your cabinet is ready to use.

STEP 17

1. Mark the position on the wall, this should be same as the position of R where are on the back of panel 1; Drilled and insert the expandable screw T by hammer;
2. Assemble the part R on the wall. Align the hole in the part R to the expandable screw T, screw in and tighten by screwdriver;
3. let the plastic belt S go through the both R and pull to tighten.



Assembly completed

M	x4	R	x2	S	x2	T	x4
							
Ø4*35mm							

WARRANTY

We strive to offer high-quality products, and we also try our best to satisfy each and every customer that orders from us with product or service as needed. We provide 30 days warranty starting from the time you receive the item. Each customer must provide a record of their order such as the order number, or item receipt for any items that are out of the warranty period you may also still receive replacement parts by purchasing them with our company if they are available.

**Are you having difficulty
with assembly? Missing parts?**

Please send email with your order No

customerservice@hulalahome.com

**For return, Please check the return policy with
the retailer or MarketPlace you bought from.**

**Appreciated your purchasing from us.
Pop up your life by our furniture piece!**